

Adjustable Stands

Overview

Streamfeeder's adjustable mounting stands are available to add even more flexibility and versatility to your Streamfeeder Friction Feeders and Placers. The height of the Universal and Heavy-Duty stands is adjustable to fit the host system. Steel construction will provide years of dependable service.

Universal Stand

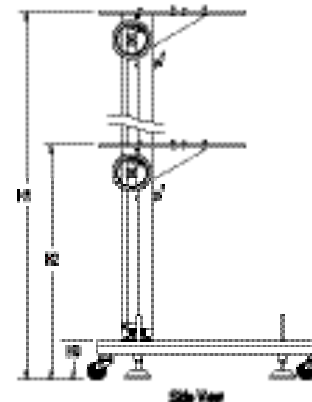

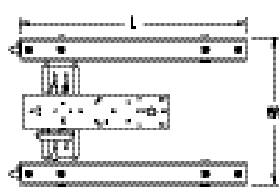
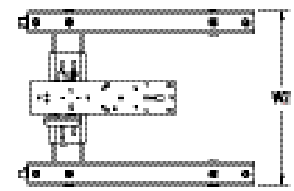

Part Numbers / Descriptions	
311-1908	Universal Stand

Dimensions					
H1 Max. Height	H2 Min. Height	H3	L	W1 Min. Width	W2 Max. Width
54" (137.16cm)	28.75" (73.02cm)	4.75" (12.06cm)	20.78" (52.78cm)	17.69" (44.93cm)	20.69" (52.55cm)



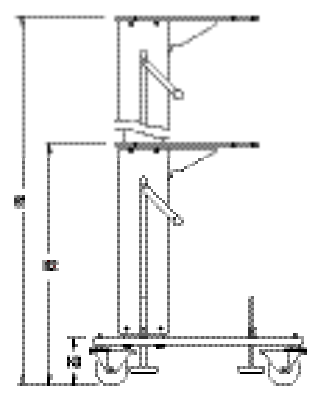

HD Stand

Part Numbers / Descriptions	
51021001	HD Stand, Short w/ Std. Base
51021023	HD Stand, Short w/ Wide Base
51021034	HD Stand, Tall w/ Std. Base
51021035	HD Stand, Tall w/ Wide Base

Dimensions					
	H1 Max. Height	H2 Min. Height	H3	L	W
Tall	56.8" (144.3cm)	41.75" (106.1cm)	6" (15.3cm)	N/A	N/A
Short	45" (114.3cm)	32" (81.3cm)	6" (15.3cm)	N/A	N/A
Std.	N/A	N/A	6" (15.3cm)	26" (66cm)	18" (45.7cm)
Wide	N/A	N/A	6" (15.3cm)	33" (83.8cm)	23" (58.4cm)

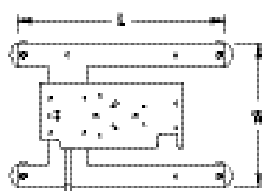

Contact our experienced sales team today for a comprehensive review of your application/product and see how our Adjustable Stands can benefit your company.

AMBEC | CBI | Fleetwood | Goldco | Nigrelli | Streamfeeder | SWF | Thiele | Tisma

