

Vacuum Conveyor

Overview

Streamfeeder's Vacuum Conveyor provides a feeding and conveying foundation for labeling, marking & coding, printing, barcode reading, and more. Open table design allows clearance for peripheral equipment. Casters allow it to be easily rolled.

Consistently feed and transport a wide variety of products at speeds up to 245 feet per minute. Can be used as an offline or inline with other systems.

Standard Features

- 65 inch deck length
- Dual vacuum belts
- Aluminum deck top
- Variable speed control
- Heavy-duty construction
- Adjustable outside belts
- Push button controls
- Adjustable product guides

Optional Features

- Streamfeeder Feeders
- Shinging Conveyor
- Diverter
- Glue systems
- Placers
- Plow Folds
- Counter
- Turnover
- Bump Turn
- Various deck lengths
- High-Temp resistant belts

Applications

- Addressing
- Attaching
- Coding
- Date Stamping
- Labeling
- Printing
- Scanning
- Tip-On/Affixing
- Tabbings
- Verification

Products

- Backer Board
- Booklets
- Brochures
- Cardstock
- Collapsed Cartons
- Envelopes
- Foil Pouches
- Folded Documents
- Folders
- Manuals
- Post Cards
- Sheet Paper
- Tyvek Pouches

Contact our experienced sales team today for a comprehensive review of your application/product and see how our Vacuum Transport can benefit your company.

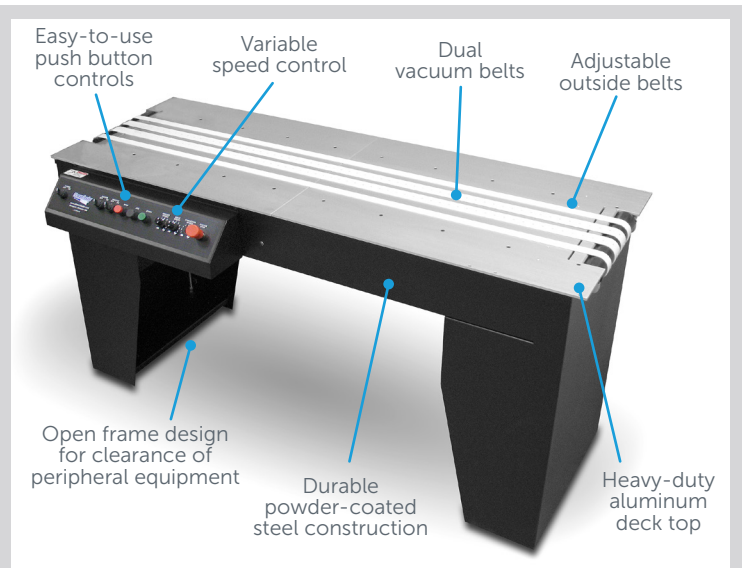

Specifications	
Transport Direction	Left to right (optional right to left)
Maximum Product Size	20" wide x 18" long (508 x 457.2 mm)
Minimum Product Size	2" wide x 3" long (50.8 x 76.2 mm)
Maximum Product Thickness	Up to .5" (12.7 mm), product dependent
Belt Speed	245 ft/min (75 m/min)
Utilities	115vac, 50/60Hz, 7A
Deck Height	33"-37" (84-91 cm)
Warranty	One year limited
Other sizes and thickness capabilities available.	

AMBEC | CBI | Fleetwood | Goldco | Nigrelli | Streamfeeder | SWF | Thiele | Tisma

