

Flighted Infeed Conveyor

Overview

Flighted Infeed Conveyors are ideal for adding automation to existing equipment or to replace manual gathering and collating. The straight drop lug allows for easy integration to belted in-feeds of new or existing packaging equipment. Streamfeeder's Modular Bases are available in standard 5-1/2' and 11' lengths.

Heavy duty casters make this in-feed portable and can be used throughout your facility as your job requirements change.

Standard Features

- Dual chain straight drop lug
- No-adjust chain tensioner
- Tool-less setups and changeovers
- Powder-coated steel and stainless steel construction
- Heavy-duty frame legs, pedestal pads and casters
- Easy to use controls (can mounted to either side)
- Left-to-right or right-to-left operation
- Extruded aluminum rails along both sides for easy integration with feeders, placers, and more

Applications

- Accumulating
- Collators
- Gathering
- Kit Fulfillment
- Polybaggers
- Wrappers

Products

- Backer Board
- Booklets
- Brochures
- Cardstock
- Envelopes
- Folded Documents
- Magazines
- Manuals
- Post Cards
- Scrap Book Materials
- Sheet Paper

Contact our experienced sales team today for a comprehensive review of your application/product and see how our Flighted Infeed Conveyor can benefit your company.

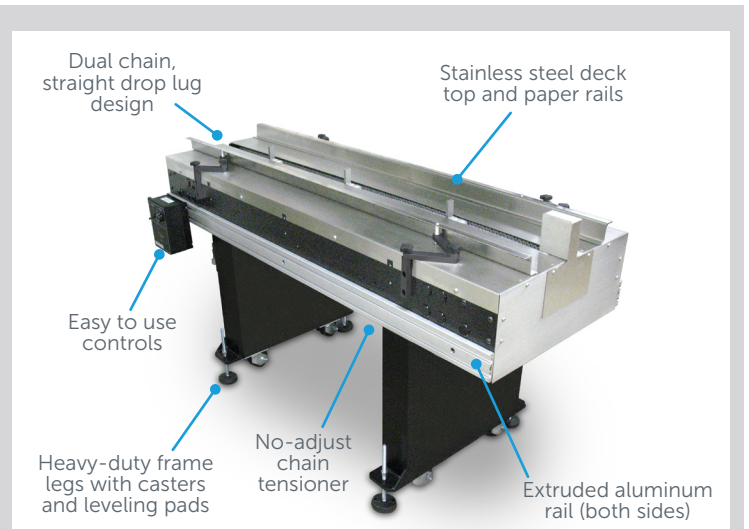

Specifications

Maximum Product Size	18" wide x 12" long (457 x 305 mm)
Minimum Product Size	3" wide x 3" long (76 x 76 mm)
Side Guide Height	2.0" (51 mm)
Speed	0-180 ft/min (457 cm/min)
Utilities	115vac, 60 Hz, 15A
Discharge Height	34-38 in (86-96 cm)
Warranty	One year limited
Other sizes and thickness capabilities available.	

AMBEC | CBI | Fleetwood | Goldco | Nigrelli | Streamfeeder | SWF | Thiele | Tisma

