

Bump Turn Conveyor

Overview

Make your equipment more versatile with Streamfeeder's Bump Turn. It runs either as a stand-alone unit or in-line with inkjets, tabbers, folders, stitchers, trimmers and more. Features include angle adjustments, left and right bump turning, variable speed, and multi-bump positioning.

The Bump Turn takes material as it is originally presented and rotates product 90 degrees either right or left at speeds up to 30,000 pieces per hour. Add a second Bump Turn unit to rotate product 180 degrees.

Features and Benefits

- Runs up to 30,000 pieces/hour
- Left or right bump option
- Adjustable multi-bump pin positioning
- Fast, simple integration
- Runs in-line with inkjets, tabbers, folders, stitchers/trimmers and more

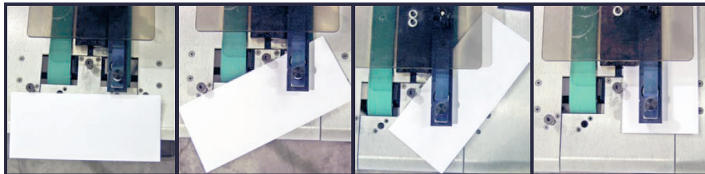

Bump Turn's pre-bump pin starts transition.

Piece makes contact with first marble located on control rack which pulls the piece smoothly.

Bump Turn belt helps continue turning the product.

Once in position, the product is ready for ink jet or tabber.

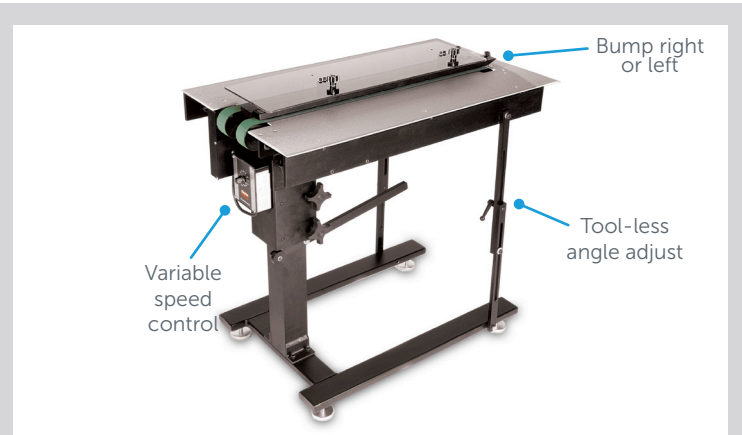

Specifications

Maximum Input Height	35" (89 cm)
Minimum Input Height	21" (53.34 cm)
Maximum Output Height	35" (89 cm)
Minimum Output Height	32" (81.28 cm)
Maximum Product Thickness	.125" (3.175 mm)
Maximum Product Size	12" long x 14" wide (305 x 357 mm)
Speed	20 to 500 ft./min. (51 to 1270 cm/min.)
Utilities	120vac, 60Hz, 3A
Product Dimensions	19.5" wide x 35.25" long x 33.25" high
Weight	49.5 lbs. (22.45 kg)
Other sizes and thickness capabilities available.	

Contact our experienced sales team today for a comprehensive review of your application/product and see how our Bump Turn Conveyor can benefit your company.

AMBEC | CBI | Fleetwood | Goldco | Nigrelli | Streamfeeder | SWF | Thiele | Tisma

