

## Pallet Stackers / Unstackers

BW Integrated Systems' versatile pallet magazine offers the following key features:

- Holds up to 12 pallets dependent upon pallet height and weight
- Pallets can feed or discharge in-line or at a right angle
- Adjustable for pallet widths ranging from 28" [711.2mm] to 60" [1524mm]
- Can be utilized for existing or new systems
- Can be used as a pallet stacker (Model R03), a pallet dispenser (Model R06) or as a combination stacker/dispenser (Model 063)
- Compact fork lift style design
- Single pallet escapement mechanism
- Air requirements: 5 CFM @ 80PSI

Contact our experienced sales teams today for a comprehensive review of your application(s) and to see how our Pallet Stackers / Unstackers can benefit your company.

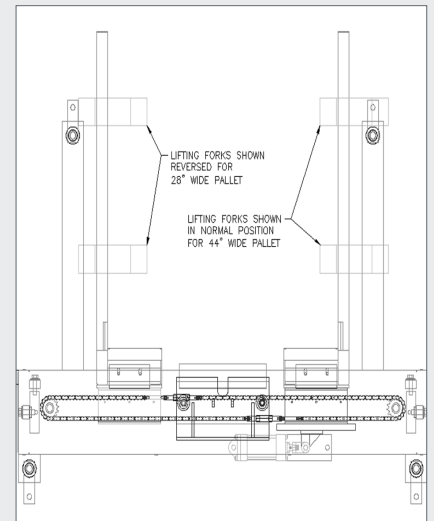

For our European office, contact:  
Plumtree Farm Industrial Estate,  
Bircotes, Doncaster  
South Yorkshire DN11 8EW ENGLAND  
t. +44 (0) 1302 711056

[AMBEC](#) | [CBI](#) | [Fleetwood](#) | [Goldco](#) | [Nigrelli](#) | [Streamfeeder](#) | [SWF](#) | [Thiele](#) | [Tisma](#)